

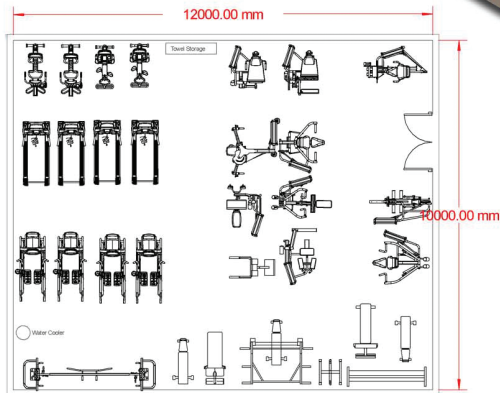

120M² (1292 FT²) – DELUXE

Serious about fitness.

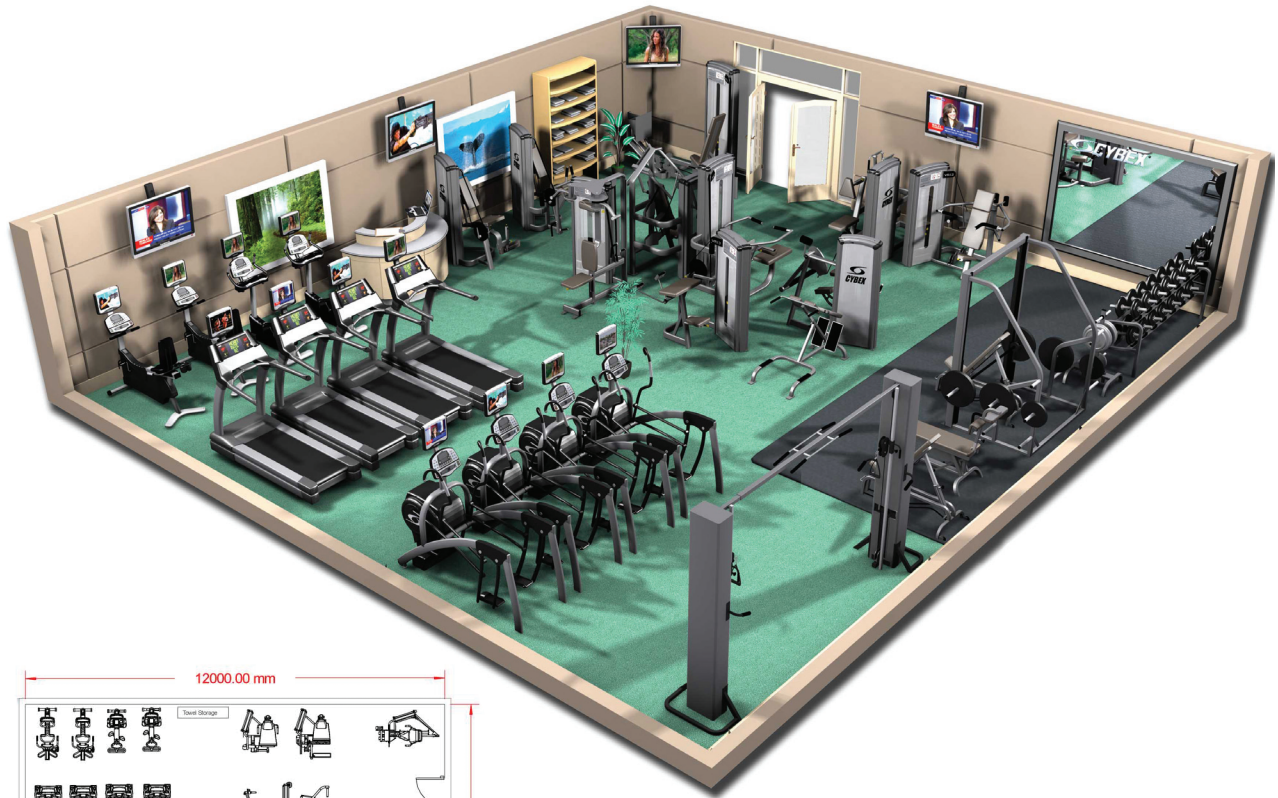

EQUIPMENT LIST

750T Treadmill
750AT Arc Trainer
750C Upright Bike
750R Recumbent Bike
VR3 Chest Press
VR3 Lateral Raise
VR3 Overhead Press

VR3 Lat Pulldown
VR3 Ab
VR3 Rotary Torso
VR3 Leg Extension
VR3 Leg Curl
VR3 Leg Press
VR3 Row

Smith Press
Bent Leg Ab Board
Flat Bench
Back Extension
Flat to 80 Adjustable Bench
Cable Crossover
Twin Tier Dumbbell Rack