

CYBEX® 60M² (645 FT²) – SUPERIOR

Serious about fitness.

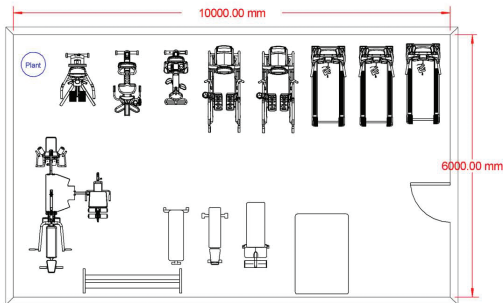

EQUIPMENT LIST

750T Treadmill
425A Arc Trainer
750C Upright Bike
750R Recumbent Bike
530S Stepper

MG525 Multi-Gym
Twin Tier Dumbbell Rack
Flat Bench
Flat to 80° Adjustable Bench
Bent Leg Abdominal Board